

# Venetian Marble

4 COLOURS

2 SIZES

1 SURFACES

A collection inspired by the Venetian terrazzo flooring used since ancient times in Greece. It then reached and became widespread in Italy, first of all thanks to the ancient Romans and then to the Venetian nobles.

CERAMICHEPIEMME  
CONTRACT

Una collezione ispirata al terrazzo alla veneziana; utilizzato fin dall'antichità in Grecia ha poi raggiunto l'Italia con larga diffusione grazie agli antichi romani prima ed ai nobili veneziani poi.

Die Kollektion ist am venezianischen Terrazzoboden inspiriert, der bereits in der griechischen Antike bekannt war und dann in Italien weite Verbreitung fand - im alten Rom wie später in den Adelshäusern Venedigs.

Une collection inspirée du terrazzo à la vénitienne. Apprécié depuis l'Antiquité en Grèce, le terrazzo a été largement diffusé en Italie par les anciens Romains d'abord et par la noblesse vénitienne ensuite.

# Venetian Marble



Informazioni Tecniche  
Technical Information



Ceramiche Piemme propone la gamma “Contract”: una linea di prodotti versatile ed essenziale, dedicata sia agli ambienti residenziali che pubblici ad alta frequentazione. La gamma “Contract” unisce una ricerca estetica sobria ad elevate caratteristiche tecniche e prestazionali, per supportare il progettista nella scelta delle finiture in tutti gli spazi della quotidianità, pubblica e privata.

#### “Contract” range

Ceramiche Piemme presents its “Contract” range: a versatile line of products. Designed for both residential and busy public environments, the “Contract” range combines a sober aesthetic style with superior technical characteristics and performances, to support the designer in choosing the finishes for all the public and private spaces of contemporary everyday life.

#### Linie “Contract”

Ceramiche Piemme präsentiert die Linie “Contract”: Eine vielseitige Produktpalette, die sich an den Wohnungsbau ebenso wie an vielbesuchte öffentliche Bereiche wendet. Sie vereint eine schlichte Optik mit hohen technischen Eigenschaften und Leistungen, die den Planer in der Wahl der Oberflächen für alle - öffentlichen wie privaten - Räume des täglichen Lebens unterstützt.

#### Collection « Contract »

Ceramiche Piemme présente sa collection « Contract » : une collection de produits polyvalents, faite pour les cadres résidentiels et publics très fréquentés. La collection « Contract » conjugue une esthétique sobre avec une très grande performance technique pour que le designer choisisse en toute liberté les finitions pour tous les espaces du quotidien, publics comme privés.

Cloud





Rainbow







# Fog

The Venetian Marble Collection presents the aesthetic effect of the Venetian terrazzo flooring combined with the technical performance of the latest generation of porcelain stoneware, thus conveying a very sober stylistic effect and high resistance to daily stress in residential and commercial environments.

Die Kollektion Venetian Marble besticht mit der optischen Wirkung des Terrazzobodens und den technischen Leistungen eines Feinsteinzeugs der neuesten Generation. Sie garantiert eine ausgesprochen schlichte Optik und dazu hohe Beständigkeit gegenüber den alltäglichen Belastungen in Wohn- und Gewerbebereichen.

La collection Venetian Marble propose la beauté du terrazzo à la vénitienne optimisée par la performance technique d'un grès cérame de dernière génération. Elle garantit ainsi un style très sobre et une très grande résistance aux contraintes quotidiennes dans les cadres résidentiels et commerciaux.

**La collezione Venetian Marble propone l'effetto estetico del terrazzo alla veneziana abbinato alle prestazioni tecniche di un gres porcellanato di ultima generazione, garantendo così un effetto stilistico molto sobrio ed un'alta resistenza alle sollecitazioni quotidiane in ambienti residenziali e commerciali.**

60x119,5 - 24"x47½" Naturale Rettificato

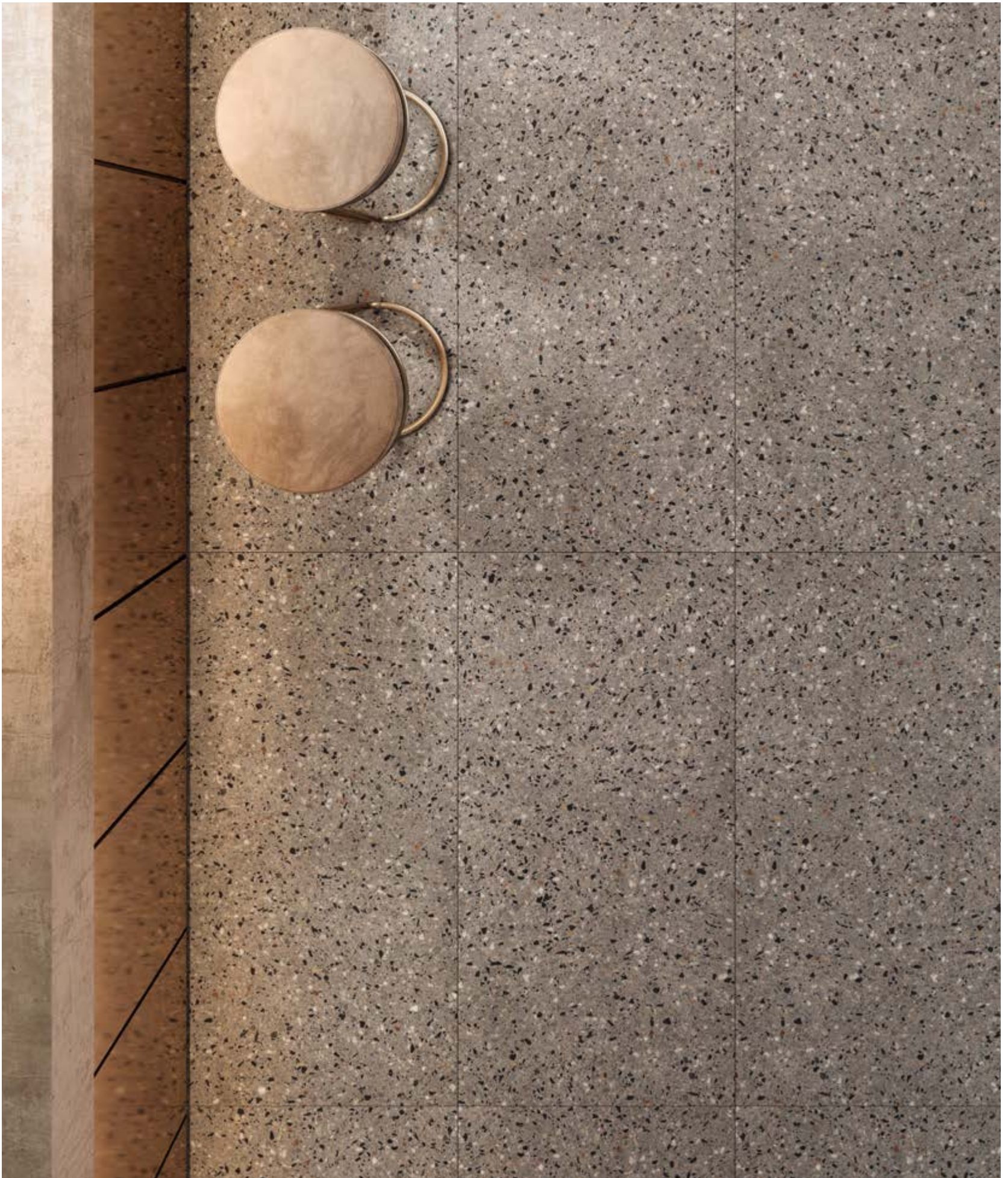

Venetian Marble  
Lounge Bar













# Informazioni Tecniche

## 4

Colori  
Colours  
Farben  
Couleurs

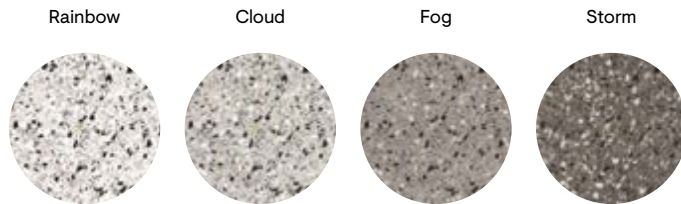

## 2

Formati  
Sizes  
Formate  
Formats

\*60×119,5    60×60  
24"×47½"    24"×24"



\*formato modulare con 60x60 e 30x60 / modular size, can be matched with 60x60 and 30x60 size /  
modulares, spricht mit dem Format 60x60 und 30x60 kombinierbares Format / format modulaire pouvant être coordonné au format 60x60 et 30x60

## 1

Spessore  
Thickness  
Stärke  
Epaisseur

±9,5

## 1

Superfici  
Surfaces  
Oberflächen  
Surfaces

Naturale

## i

Effetto Marmo  
Marble Look  
Marmoroptik  
Effet Marbre

Rivestimento  
Wall Tiles  
Wandfliesen  
Revêtement

Pavimento  
Floor Tiles  
Bodenfliesen  
Sol

Gres fine porcellanato  
Fine porcelain stoneware  
Feinsteinzeug  
Grès cérame fin

Tecnologia digitale  
Digital technology  
Digital technologie  
Technologie numérique

# Rainbow



± 9,5

\*60x119,5 - 24"x47½"

**02657** | Venetian Marble Rainbow Nat/Ret



± 9,5

60x60 - 24"x24"

**02688** | Venetian Marble Rainbow Nat/Ret

\*formato modulare con 60x60 e 30x60 / modular size, can be matched with 60x60 and 30x60 size /  
modulares, spricht mit dem Format 60x60 und 30x60 kombinierbares Format / format modulaire pouvant être coordonné au format 60x60 et 30x60



Rainbow Nat/Ret 60x119,5 - 24"x47½"

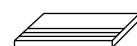
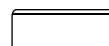

# Cloud



± 9,5



± 9,5

\*60x119,5 - 24"x47½"

**02692** | Venetian Marble Cloud Nat/Ret

60x60 - 24"x24"

**02689** | Venetian Marble Cloud Nat/Ret

\*formato modulare con 60x60 e 30x60 / modular size, can be matched with 60x60 and 30x60 size /  
modulares, spricht mit dem Format 60x60 und 30x60 kombinierbares Format / format modulaire pouvant être coordonné au format 60x60 et 30x60



Cloud Nat/Ret 60x60 - 24"x24"

Pezzi speciali  
Special pieces

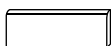

Battiscopa 8x60 ± 9,5

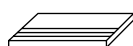

Gradino 30x60 ± 9,5

# Fog

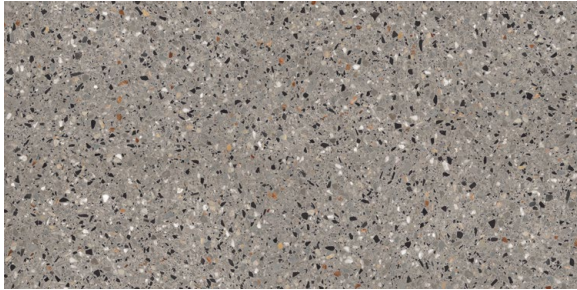

± 9,5

\*60x119,5 - 24"x47½"

**02693** | Venetian Marble Fog Nat/Ret

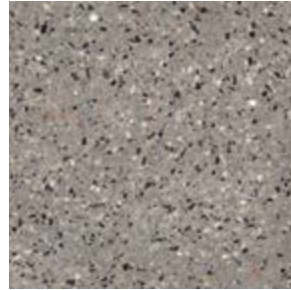

± 9,5

60x60 - 24"x24"

**02690** | Venetian Marble Fog Nat/Ret

\*formato modulare con 60x60 e 30x60 / modular size, can be matched with 60x60 and 30x60 size /  
modulares, spricht mit dem Format 60x60 und 30x60 kombinierbares Format / format modulaire pouvant être coordonné au format 60x60 et 30x60



Fog Nat/Ret 60x60 - 24"x24"

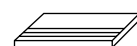
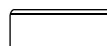

# Storm



± 9,5



± 9,5

\*60x119,5 - 24"x47½"

**02694** | Venetian Marble Storm Nat/Ret

60x60 - 24"x24"

**02691** | Venetian Marble Storm Nat/Ret

\*formato modulare con 60x60 e 30x60 / modular size, can be matched with 60x60 and 30x60 size /  
modulares, spricht mit dem Format 60x60 und 30x60 kombinierbares Format / format modulaire pouvant être coordonné au format 60x60 et 30x60



Storm Nat/Ret 60x119,5 - 24"x47½"

Pezzi speciali  
Special pieces

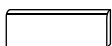



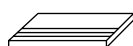



Battiscopa 8x60 ± 9,5





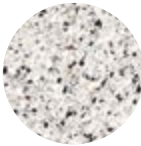



Gradino 30x60 ± 9,5

# Riepilogo Gamma







Collection  
Serie  
Gamme

	Formati Sizes						
		60x119,5 - 24"x47 1/8"	60x60 - 24"x24"	Din 51130	Din 51097	Dcof	
		± 9,5	± 9,5				
 Rainbow	Nat/Ret	02657	02688	V3	R10	A+B	>0.42
 Cloud	Nat/Ret	02692	02689	V3	R10	A+B	>0.42
 Fog	Nat/Ret	02693	02690	V3	R10	A+B	>0.42
 Storm	Nat/Ret	02694	02691	V3	R10	A+B	>0.42

	Formati Sizes	Pezzi Speciali Special Pieces	
			
		Gradino 30x60 - 12"x24"	Battiscopa 8x60 - 3 1/8"x24"
		± 9,5	± 9,5
 Rainbow	Nat/Ret	02812	02695
 Cloud	Nat/Ret	02813	02696
 Fog	Nat/Ret	02814	02697
 Storm	Nat/Ret	02815	02698

# Imballi

Packing  
Verpackung  
Emballage

Formati Sizes		± MM							
			Pezzi Scatola Pieces/Box Stck/Karton Carreaux/Boîte	Mq/Scatola Sqmt/Box Qm/Karton M2/Boîte	Kg/Scatola Kgs/Box Kg/Karton Kg/Boîte	Scatole/Paletta Boxes/Pallet Karton/Palette Boîte/Palette	Mq/Paletta Sqmt/Pallet Qm/Pallet M2/Palette	Kg/Paletta Kgs/Pallet Kg/Pallet Kg/Palette	Formato Paletta Size Pallet Format Pallet Dim. Palette
60×119,5 (24"×47½") Nat/Ret	P	9,5	2	1,434	31,00	30	43,02	930	120x80x75
60×60 (24"×24") Nat/Ret	P	9,5	3	1,080	21,50	40	43,20	860	120x80x75
Pezzi Speciali / Special Pieces									
30×60 (12"×24") Gradino Nat/Ret	P	9,5	6	1,080	21,50	36	-	-	-
8×60 (3½"×24") Battiscopa Nat/Ret	P	9,5	10	0,480 m.l. 6,00	11,00	72	-	-	-

## Pezzi Speciali

Special pieces  
Formstücke  
Pièces spéciales

Battiscopa Nat/Ret 8×60 – 3½"×24" ± 9,5

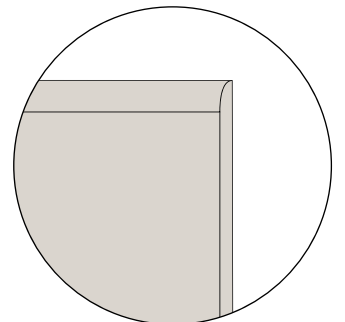
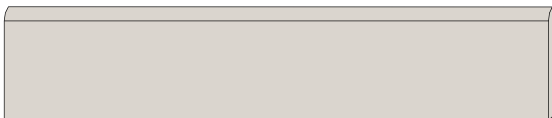



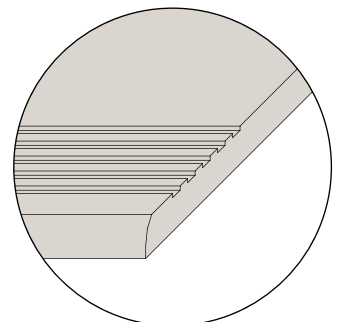







Gradino Nat/Ret 30×60 – 12"×24" ± 9,5  
(Becco civetta e fresature tecniche - bullnose edge with grooves)



# Caratteristiche Tecniche

Technical characteristics  
Technische daten  
Caracteristiques techniques

CLASSIFICAZIONE SECONDO NORME CEN/ISO GRUPPO B1A EN 14411 - ISO 13006 - CLASSIFICATION IN ACCORDANCE WITH CEN/ISO STANDARDS B1A EN 14411 - ISO 13006  
KLASSIFIZIERUNG GEMÄSS CEN/ISO-NORMEN GRUPPE B1A EN 14411 - ISO 13006 - CLASSIFICATION SELON LES NORMES CEN/ISO GROUPE B1A EN 14411 - ISO 13006

	CARATTERISTICA TECNICA TECHNICAL CHARACTERISTIC TECHNISCHE DATE CARACTERISTIQUE TECHNIQUE	NORMA NORM NORM NORME	VALORE PRESCRITTO VALUE REQUIRED NORMVORGABE VALEUR PRESCRIPTE	VALORE MEDIO MEAN VALUE MITTELWERT VALEUR MOYENNE CERAMICHE PIEMME FLOOR AND MORE	USA TESTS 	VALORE MEDIO MEAN VALUE MITTELWERT VALEUR MOYENNE CERAMICHE PIEMME FLOOR AND MORE	
	LUNGHEZZA E LARGHEZZA LENGTH AND WIDTH / LÄNGE UND BREITE / LONGUEUR ET LARGEUR		±0,6% (±2,00 MM)				
	SPESORE THICKNESS / STÄRKE / EPAISSEUR		±5% (±0,5 MM)				
	RETTILINEITÀ LATI WARPAGES OF EDGES / GERADHEIT DER KANTEN / RÉCTITUDE DES ARÊTES	ISO 10545.2	±0,5% (±1,5 MM)	CONFORME IN ACCORDANCE ERFÜLLT CONFORME	ASTM C-499 ASTM C-485 ASTM C-502	IN ACCORDANCE	
	ORTOGONALITÀ WEDGING / RECHTWINKLIGKEIT / ORTHOGONALITÉ		±0,5% (±2,00 MM)				
	PLANARITÀ FLATNESS / PLANITÄT / PLANIMÉTRIE		±0,5% (±2,00 MM)				
	ASSORBIMENTO % D'ACQUA WATER ABSORPTION WASSERAUFNAHME % ABSORPTION D'EAU %	ISO 10545.3	≤ 0,5%	CONFORME IN ACCORDANCE ERFÜLLT CONFORME	ASTM C-373	IN ACCORDANCE	
	RESISTENZA ALLA FLESSIONE BENDING STRENGTH BIEGEZUGFESTIGKEIT RÉSISTANCE À LA FLEXION	ISO 10545.4	≥ 35N/MMF	CONFORME IN ACCORDANCE ERFÜLLT CONFORME	ASTM C-648 250 LBS OR GREATER	IN ACCORDANCE	
	DILATAZIONE TERMICA LINEARE TRA 20° E 100° C LINEAR THERMAL EXPANSION BETWEEN 20° AND 100° C LINEARE WÄRMEAUSSDEHNUNG ZWISCHEN 20° UND 100° C DILATATION THERMIQUE LINEAIRE ENTRE 20° ET 100° C	ISO 10545.8	SECONDO I DATI DEL COSTRUTTORE ACCORDING TO BUILDER'S SPECIFICATIONS LAUT ANGABEN DES HERSTELLERS SELON LES ELEMENTS DU COSTRUCTEUR		= 7X10 <sup>-6</sup> C <sup>-1</sup>		
	RESISTENZA AGLI SBALZI TERMICI THERMAL SHOCK RESISTANCE TEMPERATURWECHSELBESTÄNDIGKEIT RÉSISTANCE AUX ÉCARTS DE TEMPÉRATURE	ISO 10545.9	RICHIESTA REQUEST BITTE DEMANDE	RESISTENTE RESISTANT WIDERSTEHEND RÉSISTANT			
	RESISTENZA AL GELO FROST RESISTANCE FROSTBESTÄNDIGKEIT RÉSISTANCE AU GEL	ISO 10545.12	RICHIESTA REQUEST BITTE DEMANDE	RESISTENTE RESISTANT WIDERSTEHEND RÉSISTANT	ASTM C-1026	IN ACCORDANCE	
	RESISTENZA ALL'ATTACCO CHIMICO RESISTANCE TO CHEMICAL ATTACK BESTÄNDIGKEIT GEGEN CHEMIKALIEN RÉSISTANCE À L'ATTAQUE CHIMIQUE	ISO 10545.13	SECONDO I DATI DEL COSTRUTTORE ACCORDING TO BUILDER'S SPECIFICATIONS LAUT ANGABEN DES HERSTELLERS SELON LES ELEMENTS DU COSTRUCTEUR	RESISTENTE RESISTANT WIDERSTEHEND RÉSISTANT	ASTM C-650	IN ACCORDANCE	
	RESISTENZA DEI COLORI ALLA LUCE COLOURS RESISTANCE TO LIGHT LICHTBESTÄNDIGKEIT RÉSISTANCE DES COULEURS À LA LUMIÈRE	DIN 51094	NESSUNA ALTERAZIONE NO ALTERATION KEINE VERÄNDERUNG AUCUNE ALTÉRATION	CONFORME IN ACCORDANCE ERFÜLLT CONFORME			
	RESISTENZA ALLE MACCHIE STAIN RESISTANCE FLECKENFESTIGKEIT RÉSISTANCE AUX TACHES	ISO 10545.14	≥ CLASSE 3 METODO DI PROVA DISPONIBILE TEST METHOD AVAILABLE VERFÜGBARE PRÜFMETHODE METHODE D'ESSAI DISPONIBILE	CONFORME IN ACCORDANCE ERFÜLLT CONFORME			
		DIN 51130 *	9 ≤ R ≤ 13	NAT	R10	ASTM C-1028 * COF ≥ 0,6 DRY ≥ 0,6 WET	NAT
	RESISTENZA ALLO SCIVOLAMENTO SLIPPAGE RESISTANCE RUTSCHSICHERHEIT RÉSISTANCE AU GLISSEMENT	DIN 51097 *	A,B,C	NAT	A+B	ANSI * 137.1-2012 DCOF > 0,42 WET	NAT
	PENDULUM SLIP TEST	BS EN 7976-2*	> 36 DRY > 36 WET	.....			> 0,42

\*TRATTANDOSI DI NORMATIVE NAZIONALI, I METODI DI PROVA, I REQUISITI E LE CLASSIFICAZIONI VARIANO DA PAESE A PAESE. IL VALORE ATTESO DALLA RESISTENZA ALLO SCIVOLAMENTO DELLA PRODUZIONE DI INDUSTRIE CERAMICHE PIEMME S.P.A., PUÒ VARIARE IN BASE AL LOTTO PRODUTTIVO. SPECIFICA DOCUMENTAZIONE È DISPONIBILE SU RICHIESTA.  
TEST METHODS, REQUIREMENTS AND CLASSIFICATIONS DIFFER FROM COUNTRY TO COUNTRY, ACCORDING TO THE NATIONAL REGULATIONS. THE EXPECTED VALUE OF SLIPPAGE RESISTANCE OF PRODUCTS BY INDUSTRIE CERAMICHE PIEMME S.P.A. MAY VARY DEPENDING ON THE PRODUCTION BATCH. SPECIFIC DOCUMENTS ARE AVAILABLE UPON REQUEST.  
PRÜFVERFAHREN, ERFORDERNISSE UND KLASSIFIKATIONEN SIND VERSCHIEDEN VON LAND ZU LAND, GEMÄSS DER NATIONALEN VORSCHRIFTEN. DER ERWARTUNGSWERT DER RUTSCHSICHERHEIT DER PRODUKTE VON INDUSTRIE CERAMICHE PIEMME S.P.A. KANN SICH - JE NACH DER PRODUKTIONSPARTIE - VERÄNDERN. SPEZIFISCHE UNTERLAGEN SIND AUF VERLANGEN ZUR VERFÜGUNG.  
LES MÉTHODES D'ESSAI, LES RÉQUISITIONS ET LES CLASSIFICATIONS CHANGENT DE PAYS À PAYS, SELON LES RÉGLEMENTATIONS NATIONALES. LA VALEUR ATTENDUE DE RÉSISTANCE AU GLISSEMENT DES PRODUITS DE INDUSTRIE CERAMICHE PIEMME S.P.A. PEUT VARIER EN FONCTION DU LOT DE PRODUCTION. UNE DOCUMENTATION SPÉCIFIQUE EST DISPONIBILE SUR DEMANDE.

ELENCO DELLE SERIE CERTIFICATE E CLASSIFICAZIONI DISPONIBILI A RICHIESTA - LIST OF CERTIFIED SERIES AND CLASSIFICATIONS AVAILABLE UPON REQUEST  
LISTE DER GEPRÜFTEN SERIE UND KLASSIFIZIERUNGEN AUF ANFRAGE ERHÄLTICH - LISTE DES SERIES CERTIFIÉES ET DES CLASSEMENTS DISPONIBLES SUR DEMANDE



CERAMICHE PIEMME  
FLOOR AND MORE





# Norme per la posa e la manutenzione

## Installation and maintenance instructions

### Verlegung, reiningung und pflege

### Guide a la pose et l'entretien

		TIPO DI SPORCO	INDICAZIONI PER LA PULIZIA
<ul style="list-style-type: none"> <li>Per i prodotti rettificati consigliamo una fuga di 2 mm per un migliore risultato di posa.</li> <li>Per una migliore resa estetica Piemme consiglia stuccature colorate in tinta con le piastrelle. Verificare, prima dell'utilizzo, la compatibilità ed idoneità dei riempitivi per fughe con il prodotto ceramico.</li> <li>Rimuovere le eccedenze dei riempitivi per fughe quando gli stessi sono ancora freschi.</li> <li>Attenersi scrupolosamente alle istruzioni indicate dai produttori dei riempitivi per fughe.</li> </ul>	<ul style="list-style-type: none"> <li>Per eliminare completamente i residui di posa, che potrebbero compromettere la manutenzione ordinaria e le caratteristiche del prodotto, a posa ultimata, procedere con la pulizia utilizzando prodotti adeguati, a base Acida max 3%, rispettando le indicazioni del produttore. Osservare assolutamente i limiti di tempo indicati nelle istruzioni: un contatto troppo prolungato con questi prodotti potrebbe provocare il danneggiamento della superficie.</li> <li>Gli eventuali aloni che si dovessero presentare dopo la posa di materiali lappati o levigati si potranno facilmente eliminare utilizzando un prodotto idoneo, a base Alcalina.</li> </ul>	<ul style="list-style-type: none"> <li>Riguardo l'utilizzo di materiali ceramici all'esterno, pure riconfermando l'ingelività dei prodotti Piemme in gres porcellanato, in conformità alle vigenti normative europee EN 14411/ISO 13006-ISO 10545.12, occorre attenersi ad alcune fondamentali norme previste per la posa all'esterno, atte a rendere inattaccabili al gelo i predetti pavimenti. Le condizioni più importanti da rispettare sono: le opportune pendenze, le impermeabilizzazioni, i giunti di dilatazione, e l'uso di idonei materiali per la posa.</li> <li>Decorazioni realizzate con smalti e metalli preziosi è indispensabile proteggere la superficie durante la posa, non utilizzare assolutamente prodotti abrasivi e/o acidi, ma solo acqua e sapone neutro. Il produttore non risponde di eventuali danni a questi preziosi materiali causati da "sfregamenti" durante la posa in opera. Per nessun motivo saranno accettate contestazioni relative a materiale posato.</li> </ul>	<ul style="list-style-type: none"> <li>Birra, Caffè, Gelato, Vino Gomma Pneumatico, Grassi vegetali e animali, Inchiostri, Lampostil Olii Meccanici, Residui di scotch Olio di lino, Pennarello Resine Smalti, Tintura per capelli</li> <li>Prodotti a Base Alcalina</li> <li>Cera protettiva anti-abrasione, Depositi calcarei, Macchie di ruggine</li> <li>Prodotti a Base Acida</li> <li>Cera di candela, Residui di scotch</li> <li>Solventi</li> <li>Per ulteriori informazioni specifiche consultare l'area tecnica sul sito Piemme: <a href="http://www.ceramichepiemme.it">www.ceramichepiemme.it</a></li> </ul>

		TYPE OF STAIN	CLEANING SUGGESTIONS
<ul style="list-style-type: none"> <li>For better installation results of rectified products, we suggest 2 mm joint.</li> <li>For a better aesthetic finish, Piemme recommends using jointing colours that match the tiles.</li> <li>Please check, before using, the compatibility and suitability of grouting material with the ceramic tile.</li> <li>Clean away the excess of grouting materials while they are still fresh.</li> <li>Follow carefully the instructions pointed out by the producers of tile grouting materials.</li> </ul>	<ul style="list-style-type: none"> <li>To completely eliminate installation residues, which could negatively affect routine maintenance and product characteristics once installation has terminated, proceed to clean using adequate products, with max. 3% Acid base, following the manufacturer's instructions. Always closely abide by the time limits indicated in the instructions: prolonged contact with these products may cause damage to the surface.</li> <li>Any rims that appear after installing lapped or polished materials can be easily eliminated using a suitable Alkaline-based product.</li> </ul>	<ul style="list-style-type: none"> <li>With regard to the use of ceramic materials outdoors, while once more reiterating that Piemme porcelain stoneware products are frost-proof, in compliance with applicable European standards EN 14411/ISO 13006-ISO 10545.12, a number of fundamental procedures must be followed for outdoor installation, suitable for making the aforementioned floors resistant to frost. The most important aspects are: suitable gradients, waterproofing, expansion joints, and the use of suitable installation materials.</li> <li>Decorations made with glazes and precious metals It is most important to protect the surface during installation. Never use abrasive and/or acid products, only water and neutral soap. The manufacturer disclaims liability in case of any damage to these precious materials caused by "rubbing" during installation. Under no circumstances will disputes be accepted relating to the installed material.</li> </ul>	<ul style="list-style-type: none"> <li>beer, coffee, wine, ice cream vegetable and animal fats, rubber, remains of scotch tape, grease from machines, linseed oil, felt tip pens, paints, inks, hair dye</li> <li>Alkaline-based detergent</li> <li>protective anti-abrasion wax, calcareous residuals, rust stains</li> <li>Acid-based detergent</li> <li>candle wax, remains of scotch-tape</li> <li>Solvents</li> <li>For further specific details please visit the technical area on Piemme website: <a href="http://www.ceramichepiemme.it">www.ceramichepiemme.it</a></li> </ul>

		VERSCHMUTZUNGSART	REINIGUNGSHINWEISE
<ul style="list-style-type: none"> <li>Damit sich eine bessere Verlegung von geschliffenen Produkten ergibt, empfehlen wir eine Fugenbreite von 2 mm. Für ein optisch perfektes Ergebnis empfiehlt Piemme, die Fugen farblich auf die Fliesen abzustimmen.</li> <li>Prüfen sie bitte, vor der Verwendung, die Zweckmäßigkeit und die Verträglichkeit des Fugenfüllmittels mit den Keramikfliesen.</li> <li>Bitte entfernen sie das überflüssige Fugenfüllmittel wenn es noch frisch ist.</li> <li>Folgen sie bitte sorgfältig die von dem Herstellern des Fugenfüllmittels angegebenen Bedienungsvorschriften.</li> </ul>	<ul style="list-style-type: none"> <li>Zur vollkommenen Entfernung der Verlegerückstände, die die normale Pflege erschweren und die Merkmale des Produkts beeinträchtigen könnten, nach der Verlegung geeignete Reinigungsmittel auf max. 3% Säurebasis verwenden und bei der Reinigung die Hinweise des Herstellers beachten. Die angegebenen Zeiten keinesfalls überschreiten: ein zu lange andauernder Kontakt mit diesen Produkten kann Beschädigungen der Oberfläche verursachen.</li> <li>Eventuelle nach der Verlegung von geläpptem oder geschliffenem Material sichtbare Schleier lassen sich einfach mit entsprechenden, alkalischen Produkten entfernen.</li> </ul>	<ul style="list-style-type: none"> <li>Auch wenn die Piemme-Feinsteinzeugprodukte gemäß den europäischen Normen EN 14411/ISO 13006-ISO 10545.12 frostbeständig sind, müssen beim Einsatz keramischer Materialien im Freien einige Grundregeln beachtet werden, damit die Bodenbeläge nicht vom Frost angegriffen werden können. Die wichtigsten Voraussetzungen sind: korrektes Gefälle, Abdichtung, Dehnungsfugen sowie geeignetes Verlegematerial.</li> <li>Dekore mit Glasuren und Edelmetallen Während der Verlegung muss die Oberfläche unbedingt abgedeckt werden. Es dürfen keine scheuernden und/oder säurehaltigen Produkte verwendet werden, sondern ausschließlich Wasser und neutrale Seife. Der Hersteller haftet nicht für eventuelle, während der Verlegung durch Abrieb entstandene Schäden an diesen hochwertigen Materialien. Reklamationen von bereits verlegtem Material werden in keinem Fall akzeptiert.</li> </ul>	<ul style="list-style-type: none"> <li>Bier, Wein, Eis, Kaffee Tierische oder pflanzliche Fette Gummi, Kleberbandresten Schmieröl, Tinte, Leilöl, Filzstift, Harz oder Lack, Haarfarbe</li> <li>Alkalische Reinigungsmittel</li> <li>Kratzenschutz-Wachs, Kalkablagerungen, Rostflecken</li> <li>Säure-Reinigungsmittel</li> <li>Kerzenwachs Kleberbandresten</li> <li>Lösungsmittel</li> <li>Weitere Einzelheiten finden Sie in dem technischen Bereich des Piemme website: <a href="http://www.ceramichepiemme.it">www.ceramichepiemme.it</a></li> </ul>

		TYPE DE TACHE	NETTOYAGE CONSEIL
<ul style="list-style-type: none"> <li>Pour obtenir le meilleur résultat de pose de produits rectifiés, il est conseillé de réaliser un joint de 2 mm.</li> <li>Pour parfaire l'effet esthétique obtenu, Piemme conseille de confectionner des joints de la même couleur que les carreaux.</li> <li>Vérifier avant la pose la compatibilité et convenance des remplissages pour joints avec le produit céramique.</li> <li>Enlever les surplus des remplissages pour joints alors qu'ils sont encore frais.</li> <li>Respecter scrupuleusement les instructions indiquées par les fabricants de remplissages pour joints.</li> </ul>	<ul style="list-style-type: none"> <li>Pour éliminer complètement tout résidu de pose pouvant gêner l'entretien courant et altérer les caractéristiques du produit, il est conseillé, à la fin de la pose, de procéder au nettoyage du carrelage avec des produits à base acide maximum 3% et de respecter les consignes du fabricant. Suivre impérativement les délais indiqués dans la notice car le contact trop prolongé de ces produits pourrait endommager la surface.</li> <li>Pour éliminer facilement la présence éventuelle de cernes après la pose de carreaux rodés ou polis, utiliser un produit à base alcaline.</li> </ul>	<ul style="list-style-type: none"> <li>Pour ce qui est de la pose à l'extérieur, bien que les produits Piemme en grès cérame soient ingélifs, conformément aux normes européennes EN 14411/ISO 13006-ISO 10545.12, il convient cependant de respecter quelques règles fondamentales de manière à rendre le carrelage inattaquable au gel. Les conditions les plus importantes à remplir sont: le degré d'inclinaison, l'imperméabilisation, les joints de dilatation et l'utilisation de matériaux de pose appropriés.</li> <li>Décorés réalisés avec des émaux et des métaux précieux Il est indispensable de protéger la surface pendant la pose. N'utiliser en aucun cas des produits abrasifs et/ou acides mais uniquement de l'eau et du savon neutre. La fabricant ne répond pas des dommages éventuels de ces matériaux précieux causés par le frottement pendant la pose. Aucune réclamation, quelle qu'elle soit, concernant le matériau posé ne sera acceptée.</li> </ul>	<ul style="list-style-type: none"> <li>Bière, Vin, Glace, Café, Graisses végétales et animales, Encres, Résidus de scotch, Huile de graissage, Hile de lin Crayon feutre Emaux, Teinture pour cheveux, Caoutchouc pour pneus</li> <li>Détergents à base alcaline</li> <li>Cire de protection anti abrasion, Dépôts de calcaire, Tache de rouille</li> <li>Détergents à base d'acide</li> <li>Cire de bougie Résidus de scotch</li> <li>Solvant</li> <li>Pour d'ultérieures informations spécifiques consulter le département technique du site Piemme: <a href="http://www.ceramichepiemme.it">www.ceramichepiemme.it</a></li> </ul>

Reading Guide  
Leseanleitung  
Guide a la lecture

 Spessore  
Thickness  
Stärke  
Epaisseur

Variazione nelle sfumature di colore  
Color shade variations  
Variation der Farbnuancen  
Variation des nuances de couleur

Resistenza alla scivolosità  
Skid resistance  
Rutschfestigkeit  
Resistance au glissement

P Gres fine porcellanato  
Fine Porcelain Stoneware  
Feinsteinzeug  
Grès Cérame Fin

 V1 Aspetto uniforme  
Uniform appearance  
Gleichförmiges aussehen  
Aspect uniforme

 V2 Variazione leggera  
Slight variation  
Leichte variation  
Variation légère

 V3 Variazione moderata  
Moderate variation  
Mäßige variation  
Variation modeste

 V4 Variazione casuale  
Random variation  
Zufällige variation  
Variation fortuite

DIN 51130	DIN 51097	DCOF
R10	A+B	>0,42

---

Tutti i formati sono nominali.

All sizes are nominal.

Die Formate sind Nennwerte.

Tous les formats sont nominaux.

Gli spessori riportati in questo catalogo sono nominali e possono variare a seconda dei formati e delle finiture.

The thickness mentioned on this catalogue are nominal and can be different according to the sizes and the finishes.

Die in diesem Katalog angegebenen Fliesenstärke sind nominal und können, je nach Format oder Oberfläche, verschieden sein.

Les épaisseurs reportées sur ce catalogue sont nominales et peuvent varier suivant les formats et les finitions.

I colori e le caratteristiche estetiche dei prodotti sono quanto più possibile vicini a quelli reali, nei limiti consentiti dai processi di stampa.

The colours and appearance features of the products are as close as possible to reality, within the limitation of the printing process.

Die Farben und die ästhetischen Eigenschaften der Produkte entsprechen der Wirklichkeit, innerhalb den von dem Druckverfahren erlaubten Grenzen.

Les couleurs et les caractéristiques esthétiques sont fidèles aux couleurs et caractéristiques réelles dans les limites des procédés d'impression.

Project Management  
Mktg Piemme

Finito di stampare a Gennaio 2019  
Printed in January 2019



#### Una storia tutta italiana

Piemme dal 1962, anno della sua fondazione, è protagonista indiscussa del vero Made in Italy, quello fatto di eccellenza, passione e creatività. Oggi tutti i materiali Piemme sono prodotti con tecnologia d'avanguardia come la decorazione digitale inkjet HD, la cottura in forni ad energia pulita a recupero di calore, la rettifica e levigatura in linea "one roof" e la verifica elettronica dello standard qualitativo.

#### An all-Italian story

Since 1962, the year of its foundation, Piemme has been the undisputed protagonist of real Made in Italy, that which consists of excellence, passion and creativity. Today all Piemme materials are made using cutting-edge technology such as HD inkjet digital decoration, firing in heat-recycling clean-energy kilns, "one roof" grinding and polishing line and electronic quality standard control.

#### Eine ganz italienische Geschichte

Seit dem Gründungsjahr 1962 ist Piemme ein unangefochtener Hauptakteur des echten Made in Italy: jenem, das auf Exzellenz, Leidenschaft und Kreativität gründet. Alle Piemme Erzeugnisse werden heute unter Einsatz von Spitzentechnologie produziert, wie zum Beispiel mit der digitalen Inkjet-Dekoration, dem Brennen in Öfen mit grüner Energie und Wärmerückgewinnung, dem Schleifen und Polieren in der Linie „unter einem Dach“ sowie der elektronischen Prüfung des Qualitätsniveaus.

#### Une histoire toute italienne

Depuis 1962, l'année de sa fondation, Piemme est la protagoniste indiscutée du Made in Italy, basé sur l'excellence, la passion et la créativité. Aujourd'hui toutes les phases du cycle de fabrication Piemme sont issues d'une technologie à l'avant-garde comme la décoration numérique inkjet HD, la cuisson dans des fours à énergie propre et à récupération de chaleur, la rectification et le polissage en ligne "one roof" et la vérification électronique de la qualité.

# CERAMICHE PIEMME

FLOOR AND MORE

INDUSTRIE CERAMICHE PIEMME S.P.A.  
VIA DEL CROCIALE 42/44, 41042 FIORANO (MO) - ITALY  
T. +39 0536.849111 - F. +39 0536.849402  
WWW.CERAMICHEPIEMME.IT - INFO@CERAMICHEPIEMME.IT